

## PBR Exposed Seam

24ga (min) PBRWALL over 16ga girts

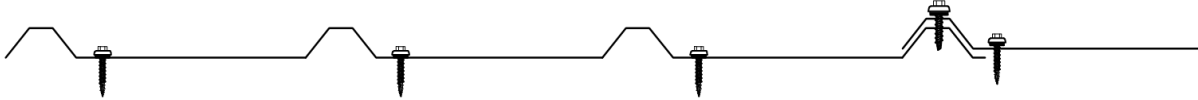

### Extreme Metal Fabricators

2160 SW Poma Dr | Palm City FL 34990

### Product Description

Rib PBR exposed fastener panel with 36" coverage and a nominal rib height of 1.25"

### Product Material

24ga (min) steel. *Corrosion resistant per FBC 1507.4.3 where required.*

### Fastener

#12 x 1.25" fastener with sealing washer. *Compliant with FBC 1506.6 where required. 1/4" sidelap fastener at 20" o.c. max*

### Girts

16ga (min) steel

## EVALUATED BY:

### David Eng, PE

Timberlake Cove, LLC  
FL PE 81377 • FL CA 33344  
1317 Edgewater Dr Ste 2339  
Orlando FL  
timberlakecove.com

This item has been digitally signed and sealed by David Eng, PE on the date indicated. Printed copies of this document are not considered signed and sealed and the signature must be verified on any electronic copies.

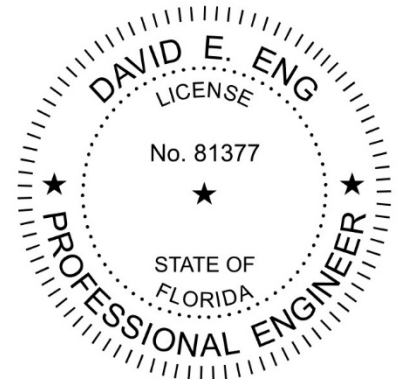

**Maximum Allowable Loads & Installation Requirements:**

Method	Fastener Pattern	Fastener Spacing	Allowable Pressure
Method A	#12 x 1.25" fastener in 12"-12" pattern, (1) per rib	60" o.c	±53.3 PSF
Method B	#12 x 1.25" fastener in 12"-12" pattern, (1) per rib	30" o.c.	+160 PSF   -146.6 PSF

A factor of safety of 2 has been applied.

These pressures may be interpolated for intermediate purlin/fastener spacing, and/or the following table may be referenced:

Purlin spacing	Pressure (PSF)	
	(+)	(-)
60"	53.3	53.3
54"	74.64	71.96
48"	95.98	90.62
42"	117.32	109.28
36"	138.66	127.94
30"	160	146.6

**Technical Documentation:** This product has been tested to the TAS 201 & TAS 203 standard by Intertek Testing (TST-1527), report M5026.01-450-18. Test used with permission.

**Compliance Statement:** This product as described has demonstrated compliance with Florida Building Code 2023, 1709.2 (non-HVHZ) and 1709.2/1626.1 (HVHZ), as required by FL Rule 61G20-3, method 1D.

This product as described has been tested and demonstrated compliance with:

- TAS 201 – Impact Test Procedures
- TAS 203 – Criteria for Testing Products Subject to Cyclical Wind Pressure Loading

**Design Process:** Compare the maximum allowable loads on page 2 to the ASD uplift pressures for the project to determine sufficiency and installation requirements.

Alternatively, as an option, the load tables in this report provides one prescriptive option for the fastening requirement for the applicable wind loads for roofs within the parameters described.

For roofs outside of the listed parameters, design wind loads shall be determined as required by FBC 1609, ASCE 7, or other design code in force, using allowable stress. These load tables are based on ASCE 7-22. Use of these tables assumes that the structure is: Enclosed and conforms to wind-borne debris provisions and is a regular shaped building and is not subject to across-wind loading, vortex shedding, or instability; nor does it have a site location for which channeling or buffeting warrant consideration

Engineering analysis may be completed by other licensed engineers for project specific approval by local authorities having jurisdiction.

**Notice to Other Entities:** This product approval applies only to metal panel products produced by Extreme Metal Fabricators. Other manufacturers, distributors, installers, engineers, architects, or other parties relying on this approval for any product not produced by Extreme Metal Fabricators assume full, strict product liability. Traceability of coil, audited quality assurance programs, and compliance with FAC 61G20-3 are solely the responsibility of the entity relying on this approval. Extreme Metal Fabricators assumes no liability for non-compliance or product performance for any product relying on this approval but not manufactured by Extreme Metal Fabricators.

**Certification of Independence:** David Eng, PE and Timberlake Cove, LLC do not have, nor will acquire a financial interest in any company manufacturing or distributing products under this evaluation. The same entities do not have, nor will acquire, a financial interest in any other entity involved in the approval process of the product.

**Exclusions and Limitations:** Design of deck and roof structure (to include attachment of plywood or wood plank) shall be completed by others. Fire classification and shear diaphragm design are outside the scope of this evaluation. Accelerated weathering/salt spray is outside the scope of this evaluation.

This report is limited to compliance with structural wind load requirements of FBC 1504.3.2, as required by Rule 61G20-3. Neither Timberlake Cove nor the manufacturer shall be responsible for any conclusions, interpretations, or designs made by others based on this evaluation report. This report is limited solely to documenting compliance with Rule 61G20-3, and makes no express or implied warranty regarding performance of this product. Installation shall be subject to the local building code and authority having jurisdiction; this report shall not be construed to supersede local codes in force.

**Use of Load Tables:** These load tables are provided as a courtesy to provide one possible prescriptive option for a generic, typical structure without calculating the design pressures.

For structures outside the parameters of these load tables (e.g. height above 30 feet), calculate the required allowable design pressure and compare to the maximum allowable loads shown on page 2. These load tables shall not be construed to in any way limit the installation of this product to the cases shown.

**Instructions:**

Select the appropriate load table that applies to the structure in question.

Determine the design wind speed for the project location.

Use the attachment method indicated for that windspeed within each roof zone.

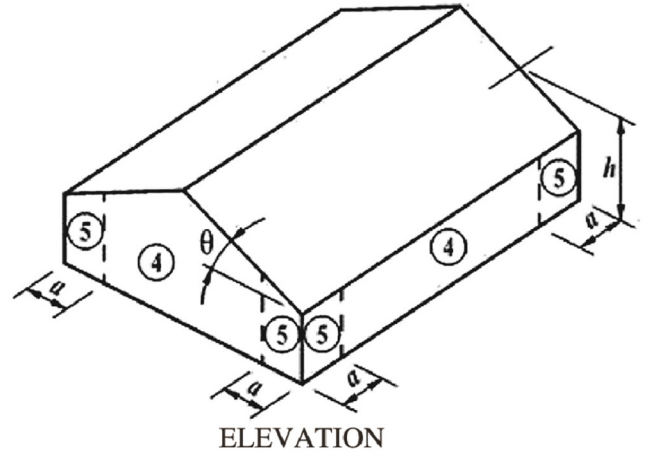

12"-12" PATTERN  
USE OC SPACING SHOWN IN TABLE

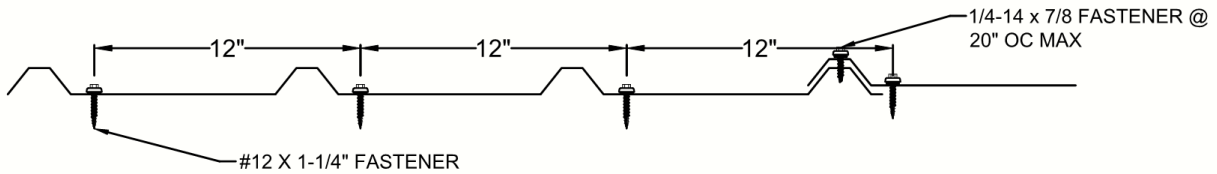

Use this load table for structures which meet the following criteria:

Are located in **Exposure B** area

Have a mean Roof Height of **30 feet or less**

**FL39837.01: 24ga PBR Wall Panel on 16ga steel framing**

Wind	105	110	120	130	140	150	160	170	180	190	200
<b>Zone 4:</b>	60	60	60	60	60	60	60	60	60	60	60
<b>Zone 5:</b>	60	60	60	60	60	60	60	60	60	60	48

Use this load table for structures which meet the following criteria:

Are located in **B, C, or D exposure** area

Have a mean Roof Height of **30 feet or less**

**FL39837.01: 24ga PBR Wall Panel on 16ga steel framing**

Wind	105	110	120	130	140	150	160	170	180	190	200
<b>Zone 4:</b>	60	60	60	60	60	60	60	48	48	48	48
<b>Zone 5:</b>	60	60	60	60	60	48	48	48	48	42	42